

IMPORTANT

1. Always include complete heater model and serial number so that any specification change can be considered for parts shipment. It can save time and expense.
2. Specifications are subject to change without notice.
3. We reserve the right to substitute functional replacements.
4. Order either by Kit or Component Part No.

Replacement Parts

Form RZ-NA-P-X/XE/RX/RPV

Obsoletes Form RGM 705 (Version A)

APPLIES TO: Replacement Parts for Models listed in the Index including Models with prefix "C", "H", and "HC"



Index Reference by Page No.	Indoor		Outdoor				Indoor	Outdoor
	Duct Furnace	Packaged Systems	Duct Furnaces		Packaged Systems (Models discontinued as of 1990)		Unit Heaters (Obsolete)	Evaporative Cooler (Obsolete)
	X	XE/XJ	RX	RPV	RXE/RXJ	RPBE/RPVE/RPVJ/REB/REBJ	UA/XA/ XB*	RAM
Model Series Designations (including Models with prefix "C", "H", or "HC")	X	XE/XJ	RX	RPV	RXE/RXJ	RPBE/RPVE/RPVJ/REB/REBJ	UA/XA/ XB*	RAM
Baffles (Heat Exchanger)	10	10	10	10	10	10	--	--
Blower	--	11	--	--	11	11	--	--
Burner Rack and Carryovers	8	8	8	8	8	8	8**	--
Cabinet Parts (Blower)	--	12	--	--	13	13	--	--
Cabinet Parts (Heater)	4	4	4	6	4	4, 6	--	28
Carryover Regulator	8	8	8	8	8	8	--	--
Condensate Drain Kit	27	27	27	27	--	--	--	--
Contactors	--	14	--	--	14	14	--	--
Damper and Damper Controls	--	20-21	--	--	20-21	20-21	--	--
Door Latch Kit	--	13	--	--	13	13	--	--
Downturn Plenum Cabinet	--	--	--	--	20	20	--	--
Drives	--	19	--	--	19	19	--	--
Electrical Components	22-25	22-25	22-25	22-25	22-25	22-25	--	28
Fan Blades	--	--	--	--	--	--	18	--
Fill & Drain Kits (Option CT)	--	--	--	--	--	--	--	28
Filters and Filter Racks	--	12	--	--	13	13	--	28
Firestat	--	23	--	--	23	23	--	--
Flue Restrictors	--	--	6	--	6	6	--	--
Freezestat	--	24	--	--	24	24	--	--
Heat Exchanger	10	10	10	10	10	10	--	--
Limit Controls & Shields	22	22	22	22	22	22	--	--
Manifolds	8	8	8	8	8	8	--	--
Motors (Blower or Fan)	--	14-16	--	--	16-18	16-18	18	--
Pilots	26	26	26	27	26	26-27	26	--
Pressure Switch (air proving)	--	--	24	24	24	24	--	--
Pressure Switch (combustion air)	--	--	--	7, 22	--	7, 22	--	--
Pressure Switch (dirty filter)	--	24	--	--	24	24	--	--
Pressure Switch (gas)	23	23	23	23	23	23	--	--
Relays	23-24	23-24	23-24	23-24	23-24	23-24	23-24	--
Remote Console (Option RC)	25	25	25	25	25	25	--	--
Serial Number Designation	2	2	2	2	2	2	2	--
Starters & Starter Heaters	--	14-16	--	--	16-18	16-18	--	--
Switch, Blocked Vent	22	22	--	--	--	--	--	--
Switches, Disconnect & Toggle	25	25	25	25	25	25	25	--
Tape for Curbs	--	--	27	27	27	27	--	--
Transformer	24	24	24	24	24	24	--	--
***Valves (Shutoff)	8	8	8	8	8	8	8	--
Venters	--	--	--	6	--	6	--	--
Vertical Vent Kit (Option CC3)	--	--	--	6	--	6	--	--
Weatherhood (Outside air hood)	--	--	--	--	20	20	--	--
Z-Baffles (Option ZZ)	--	--	4-5	--	4-5	--	--	--

* Replacement parts for obsolete unit heaters are limited. Cabinet parts are not available. ** Not available for Model UA.

REFERENCES:

Replacement Parts and Service Forms, Form RZ-NA

P-PILOTS, Pilots

P-STATS, Thermostats and Accessories

P-GC, Gas Conversion

P-LTR-TUBES, Burner Rack Carryover and Lighter Tubes

P-RG/RP/RBL, Parts for Model Series RG and RP

P-FAN-LIMIT, Fan and Limit Controls

***P-VALVES, Serial Nos., Gas Valves, Ignition Controllers, and Maxitrol Gas Controls

P-VENTER, Power Venter for Model Series X and XE

737, Parts for Model PAK

CP-X-CONV, Convert Model Series X and RX with G19 or T32 to G770

CP-RPV-CONV, Convert Model Series RPV with G29 to G770

CP-RPV-PS, Pressure Switch Kit for Model Series RPV

CP-X/SC-IGN, Convert Model Series X and RX with G60 to G770

CP-EEDU/RPV/XLB-IGN, Convert Model Series RPV with G60 to G770

Installation/Operation Forms for currently manufactured Models, Form RZ-NA

I-OUTDOOR-DUCT, Models RX and RPV

I-XE/RGB/RPB, Model XE

I-X, Model X

Heat Exchanger and Components

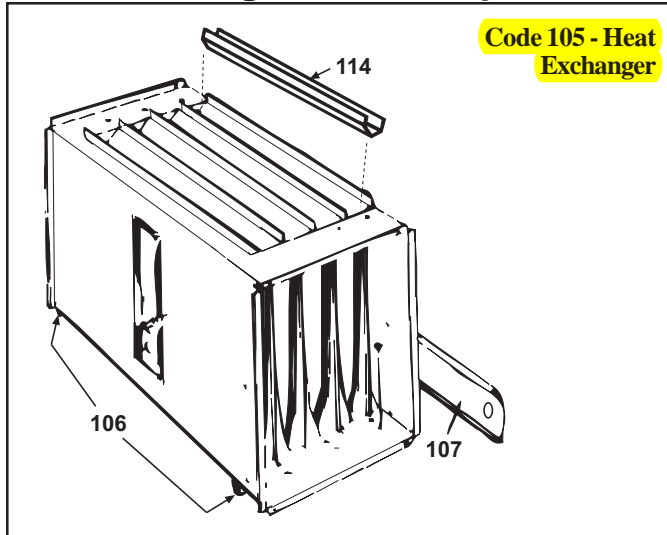

Heat Exchanger Directional Air Baffles

Models X, CX, RX, CRX, RPV, CRPV Series 5, 6, 7 and 8 and packaged systems with these duct furnaces as components are equipped with a heat exchanger directional air baffle assembly as shown in the illustration on the left below.

When replacing a heat exchanger, check to see if the baffle assembly can be salvaged. If the baffle assembly cannot be salvaged, it will be necessary to order the parts (Codes 108-113) in the quantities listed and assemble and install replacement baffles. (These parts must be ordered separately and installed in the field. Baffles cannot be factory installed.)

Models HX, HCX, HRX, HCRX, HRPV, HCRPV Series 5, 6, 7, and 8 and packaged systems with "H" or "HC" suffix are equipped with only a rear top baffle support (Code 111) and a rear top baffle (Code 112) as shown in the lower left illustration. If these parts cannot be salvaged, order and install replacements.

These parts must be ordered separately and installed in the field.



Code	Description	Qty	75, 100	125	150, 175	200, 225	250, 300	350	D300, 400	
105	Heat Exchanger	X, CX - Aluminized Steel	1	9895	9855	9817	9779	9743	9707	9514
		X, CX - 409 Stainless Steel	1	19429	19430	19431	19432	19433	19434	19435
		X, CX - 321 Stainless Steel	1	19438	19439	19440	19441	19442	19443	19444
		RX, CRX - Aluminized Steel	1	44301	44304	44307	44310	44313	44316	44319
		RX, CRX - 409 Stainless Steel	1	44302	44305	44308	44311	44314	44317	44320
		RX, CRX - 321 Stainless Steel	1	44303	44306	44309	44312	44315	44318	44321
		RPV, CRPV - Aluminized Steel	1	--	44304	44307	44310	44313	44316	44319
		RPV, CRPV - 409 Stainless Steel	1	--	44305	44308	44311	44314	44317	44320
		RPV, CRPV - 321 Stainless Steel	1	--	44306	44309	44312	44315	44318	44321
106	Burner Rack Slide Rail	All Models Series 5, 6, 7, & 8	2	9897	9857	9819	9781	9745	9709	9517
107	Burner Rack Back Brace	All Models Series 5, 6, 7, & 8	1	9525	9525	9525	9525	9525	9525	9525
108	Bracket for Bottom Baffle Support	X, RX, RPV Series 5, 6, 7, and 8	1	55101	55101	55101	55101	55101	55101	55101
			➤	(2)	(2)	(2)	(2)	(4)	(4)	(4)
109	Finger Baffle	X, RX, RPV Series 5, 6, 7, and 8	➤	45399	45399	45399	45399	45399	45399	45399
			➤	(3)	(3)	(6)	(8)	(11)	(13)	(15)
110	Bottom Baffle Support	X, RX, RPV Series 5, 6, 7, and 8	1	46478	46484	46489	46494	46499	46504	46509
111	Rear Top Baffle Support	All Models Series 5, 6, 7, & 8	1	55103	55104	55106	55108	55110	55112	55114
112	Rear Top Baffle	All Models Series 5, 6, 7, and 8	1	55228	55229	55231	55233	55235	55237	55239
		Series 5W and 6W	1	55228	55228	--	--	--	--	--
113	Side Finger Baffle	X, RX, RPV Series 5, 6, 7, and 8	2	55128	55128	55128	55128	55128	55128	55128
114	Heat Exchanger Tube Baffles ("V" Type Baffles)	Series 8 - All Models	➤	85727	85727	85727	85727	85727	85727	85727
			➤	(4)	(4)	(7)	(9)	(12)	(14)	(16)
		Prior to Series 8 - "C" Models Only	➤	85727	85727	85727	85727	85727	85727	85727
			➤	(4)	(4)	(7)	(9)	(12)	(14)	(16)

